



**! IMPORTANT!**

**Please read instructions thoroughly  
and in their entirety before beginning installation.**

These pages will address typical installations to wood supporting structure. Connections to concrete will be very similar. Some systems have custom connections that may require additional help.

**BEFORE making in-field modifications to your railing system, contact AGS Stainless.**

Open each box and take an inventory of the contents. **Notify AGS immediately if the quantities do not match those on the packing list.**

**We Are Here to Help**

You can reach us at (888) 842-9492, Mon.-Fri. 8-4:30 PST.

If you have any questions at any time during the installation, do not hesitate to call us.

Disclaimer: AGS Stainless, Inc. Clearview® Railing Systems are designed by a professional engineer to meet the requirements of the latest international building codes (IBC, IRC). It is the responsibility of the customer to verify compliance with local governing codes. AGS recommends having a qualified entity review or design the supporting structure to ensure it is capable of resisting the loads imparted on it by the railing system.

## You Will Need

- Tape measure
- Masking tape
- Power drill
- 1/8", 3/16" Drill bits
- 24" Level
- 1/2", 9/16" Sockets
- (2) 7/16" Wrenches
- Small vice-grips
- 5/32" Allen wrench

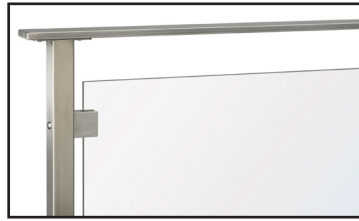

### FOR FLAT TOP RAIL

- C-clamp
- Stubby Phillips screwdriver



### FOR ROUND TOP RAIL

- Caulking gun
- Acetone
- Non-abrasive cleaning cloth

## Locating Component ID Numbers

Posts and top rail segments/components are etched to correspond to their ID numbers on the installation drawings.

### Top Mount Posts

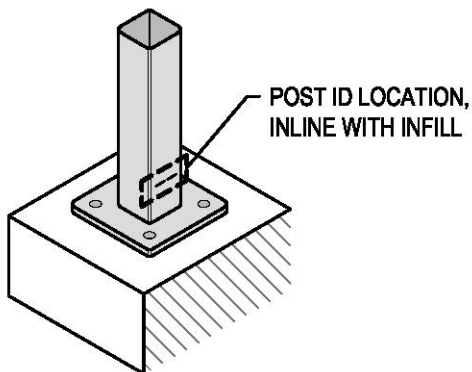

### Side Mount Posts

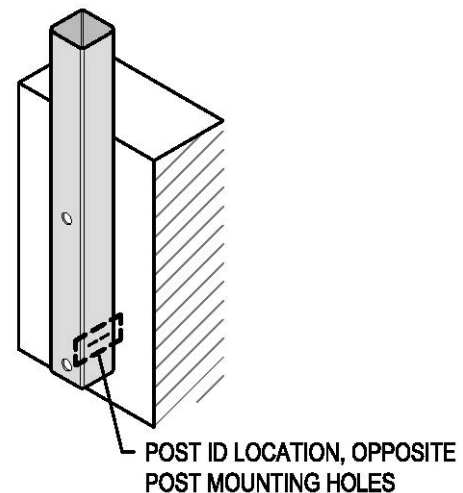

## Top Rail Components

Top rail components are etched at one end.

Note: Due to fabrication processes, curved top rail pieces are not etched.



# Installing the Posts

## Side Mount Posts

- A. Begin your installation where designated on the Installation Guide drawings, or at a corner/end post. Lay out the posts and top rail segments for a small area according to the plan. Starting small in scope will allow you to get familiar with the system.
- B. Use the Installation Guide plan & details to identify and locate the post; mark the location of the upper mounting hole.
- C. Drill a pilot hole using the 3/16" drill bit.
- D. Install the post with the upper 3/8" lag screw.
- E. Plumb the post and drill the pilot hole for the lower lag screw.
- F. Install the lower 3/8" lag screw and finish by tightening both lag screws ensuring the post is plumb in all directions.

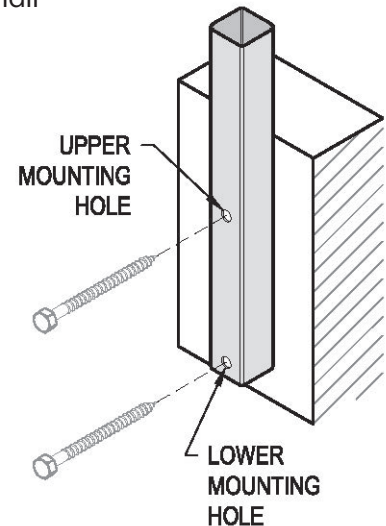

## Top Mount Posts

- A. Begin your installation where designated on the Installation Guide drawings, or at a corner/end post. Lay out the posts and top rail segments for a small area according to the plan. Starting small in scope will allow you to get familiar with the system.
- B. Use the Installation Guide plan & details to identify and locate the post. Orient it properly to the edge of the mounting surface.
- C. Drill a pilot hole with the 3/16" drill bit in one of the four mounting holes, then install a 5/16" lag screw.
- D. Install the remaining lag screws in the same manner ensuring the post is plumb in all directions.

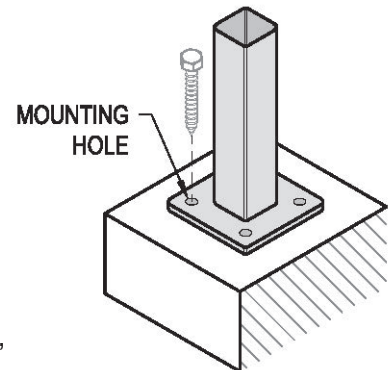

**TIP:** Centering a shim under the base plate will facilitate plumbing the post if mounting surface is uneven.

### Repeat Step 1 or Proceed?

- Flat or Wood Top Rail - Repeat Step 1 until all posts are installed, then proceed to Step 2.
- Round Top Rail - After installing the first post, proceed to Step 2.



# Installing the Top Rail

## Flat Top Rail

- A. Begin with the top rail component that corresponds to the first post(s) installed and position it atop the post.
- B. Center the top rail on the mounting plate and clamp it to the post.

**TIP:** Placing a soft cloth between the clamp jaws and component will prevent marring the stainless steel.

- C. Apply steady pressure at medium speed and carefully drill a hole with the #18 drill bit (provided) into the underside of the top rail.
- D. Use the cutting tap (provided) to cut threads into the hole. Install a #10-32x3/8" screw. Repeat on the other side of the post. Continue to next post until you reach the end of the top rail component.

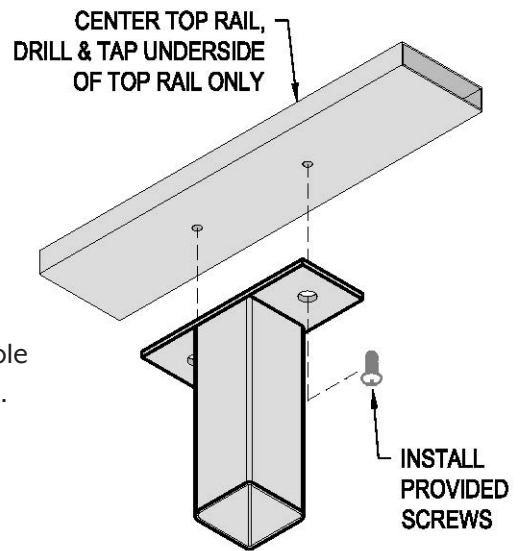

- E. Slide the patented two-piece splice block, holes down, into the open end of the installed top rail component. Align the holes of the splice block with the holes on the underside of the top rail and, with two set screws (provided), spread the splice block just enough so that it stays in place.

- F. Slide the next top rail component over the exposed splice block and finish the splice connection with two set screws. Tighten and adjust set screws to create a smooth transition on the top side of the top rail.

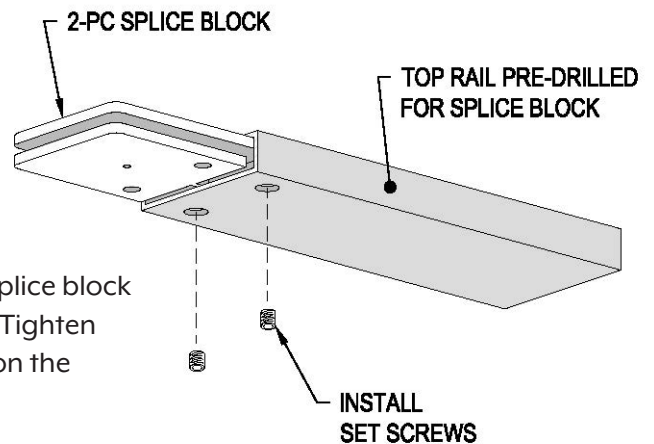

**NOTE:** Straight lengths of top rail will follow the pitch of the mounting surface, so leveling them is unnecessary.

## Round Top Rail

Each round top rail joint has a male to female connection. Wipe down the mating surfaces with a clean cloth and acetone prior to assembly.

- A. Find the proper rail component (i.e. straight segment, elbow) per the Installation Guide drawings. Apply bonding agent (provided) to the inside of each open (female) end. Twist the component onto the receiving (male) end to ensure an even distribution of the bonding agent.
- B. Take the next post and, with a twisting motion (to evenly distribute the bonding agent) slide it into the open end of the top rail component. Secure post following procedure outlined in Step 1: Installing the posts.
- C. Clean off excess bonding agent with acetone and a soft cloth.
- D. Repeat process until all posts and top rail components in the run are installed. Proceed to step 3.

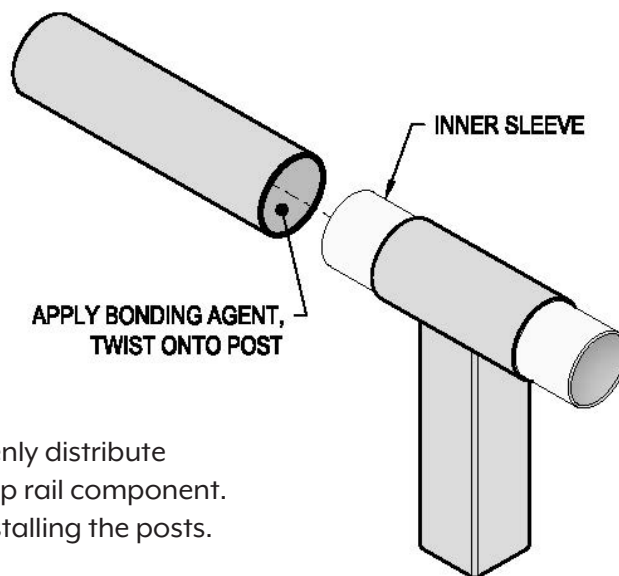

## Wood Top Rail (Not Provided)

Your wood top rail should meet the requirements of your local code. Talk to your top rail provider about wood species, shapes and screw size for attachment to the posts. A minimum cross section with a 1 ½" wide flat spot on the bottom allows for a nice connection at the posts.

- A. Install the wood top rail so that the full strength of the wood section is developed at each splice. AGS recommends consulting a wood professional.

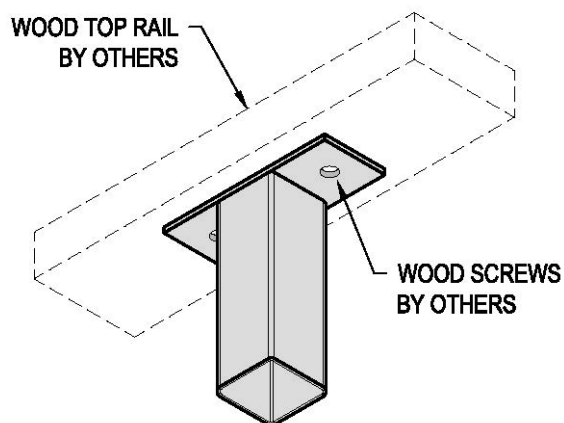



# Installing the Infill

## Before You Begin

- **These instructions reference glass clamps, however any infill such as wire or mesh will install in similar fashion. All infill panels should meet the requirements of your local code. Talk with your infill provider about panel type, thickness, size, etc.**

## Infill Panels up to 3/8" Thick

- A. Using a 5/32" hex wrench, disassemble several clamps.
- B. **For end/corner posts:** Install clamps on inside face of post using the 5/16" x 2" bolt & hex nut (provided), ensuring clamp is vertical when installed.

**For intermediate posts:** Install clamps on both sides of post using the 5/16" x 2 1/4" bolt & hex nut (provided), ensuring clamps are vertical when installed.

- C. Make sure the correct rubber inserts are in place for the thickness of infill you are using:  
 6mm inserts for 1/4" infill panels  
 8mm inserts for 5/16" infill panels  
 10mm inserts for 3/8" infill panels
- D. With all clamps installed and ready to receive the panel, set panel in place and secure with the face plate of the clamp.

**TIP:** Placing 2x4's on the floor/deck creates a perfect support for the panel while you tighten the clamps down.

- E. Repeat until all panels have been securely installed.

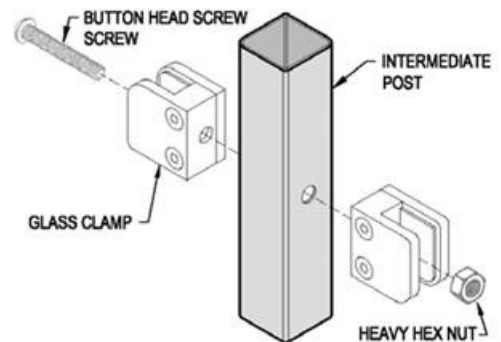
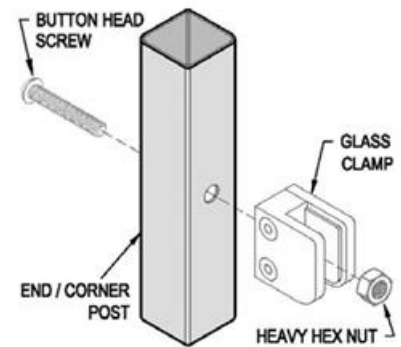

## Infill Panels Over 3/8" Thick

**NOTE:** Large clamps accommodate panel thicknesses 12.7mm – 13.52mm. Support pins are provided and are recommended for use on AGS railing systems. Install using the standard clamp instructions, with the following exceptions:

- A. For end/corner posts: use the 5/16" x 2 1/4" bolt & hex nut (provided).
- B. For intermediate posts: use the 5/16" x 2 3/4" bolt & hex nut (provided).

# Thank You For Choosing AGS Stainless, Inc.

AGS Stainless is committed to providing five-star customer service. If you have any comments, questions or concerns, please do not hesitate to contact us. We value your feedback and welcome the opportunity to connect and learn about your experience.



Tell us about your great experience installing your custom railing system, and please consider writing a review. We are grateful to our customers who upload photos and rate our service on Google, Facebook, and Houzz.

