

1 EXAMPLE POST LAYOUT
PLAN VIEW

NOTES:

1. TOP RAIL NOT SHOWN FOR CLARITY.
2. ALL PARTS AND COMPONENTS MADE WITH 316 STAINLESS STEEL UNLESS NOTED OTHERWISE.

LEGEND

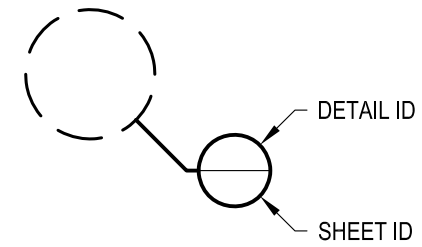

□ CORE MOUNT POST

□ □ CORE MOUNT DOUBLE POST

⊕ CENTERLINE

F.F. FINISHED FLOOR

TYP TYPICAL CONDITION APPLIES ELSEWHERE AT SIMILAR CONDITIONS

OWNER	GLACIER CM42RC
SCALE	NONE
DATE	2024
DESIGNER	AGS
SHEET	1 OF 4

GLACIER SPECIFICATION DRAWING
** COMMERCIAL **

42" CORE MOUNT - ROUND TOP

7873 NE DAY ROAD
BAMBRIDGE ISLAND, WA 98110
PHONE - (888) 842-9492
FAX - (206) 842-8179
WWW.AGSSTAINLESS.COM



NOTES:

1. DECK STRUCTURE CAN VARY GREATLY. IT IS THE RESPONSIBILITY OF THE CUSTOMER TO VERIFY THAT THE SUPPORTING STRUCTURE IS ADEQUATE TO MEET THE LOAD REQUIREMENTS OF THE GOVERNING BUILDING CODE(S). *AGS Stainless Inc.* RECOMMENDS CONSULTING A DESIGN OR CONSTRUCTION PROFESSIONAL TO ADDRESS THESE ISSUES.

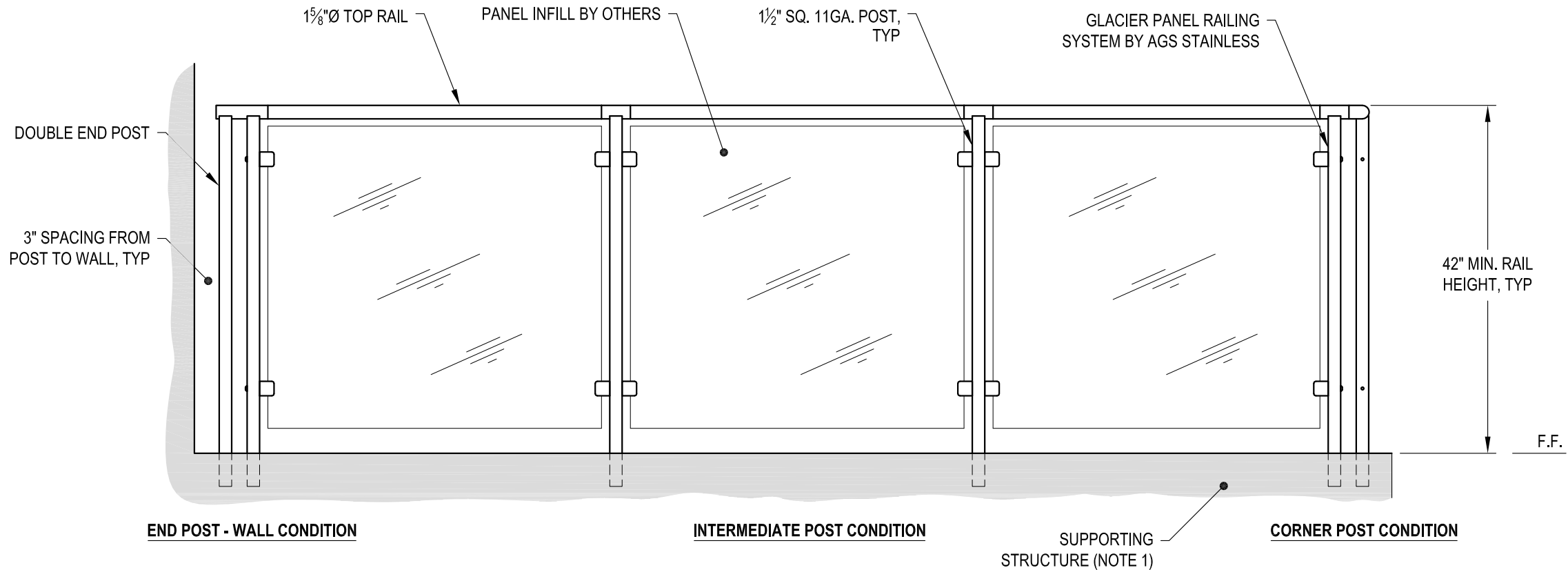

A TYPICAL RAILING CONDITION ELEVATION

DWG#	GLACIER CM42RC	DATE	2024
	SCALE		NONE
DESIGNER	AGS	SHEET	2 OF 4

GLACIER SPECIFICATION DRAWING
** COMMERCIAL **

42" CORE MOUNT - ROUND TOP

7873 MEADY ROAD
BAMBRIDGE ISLAND, WA 98110
PHONE - (888) 842-9492
FAX - (206) 842-8179
WWW.AGSSTAINLESS.COM



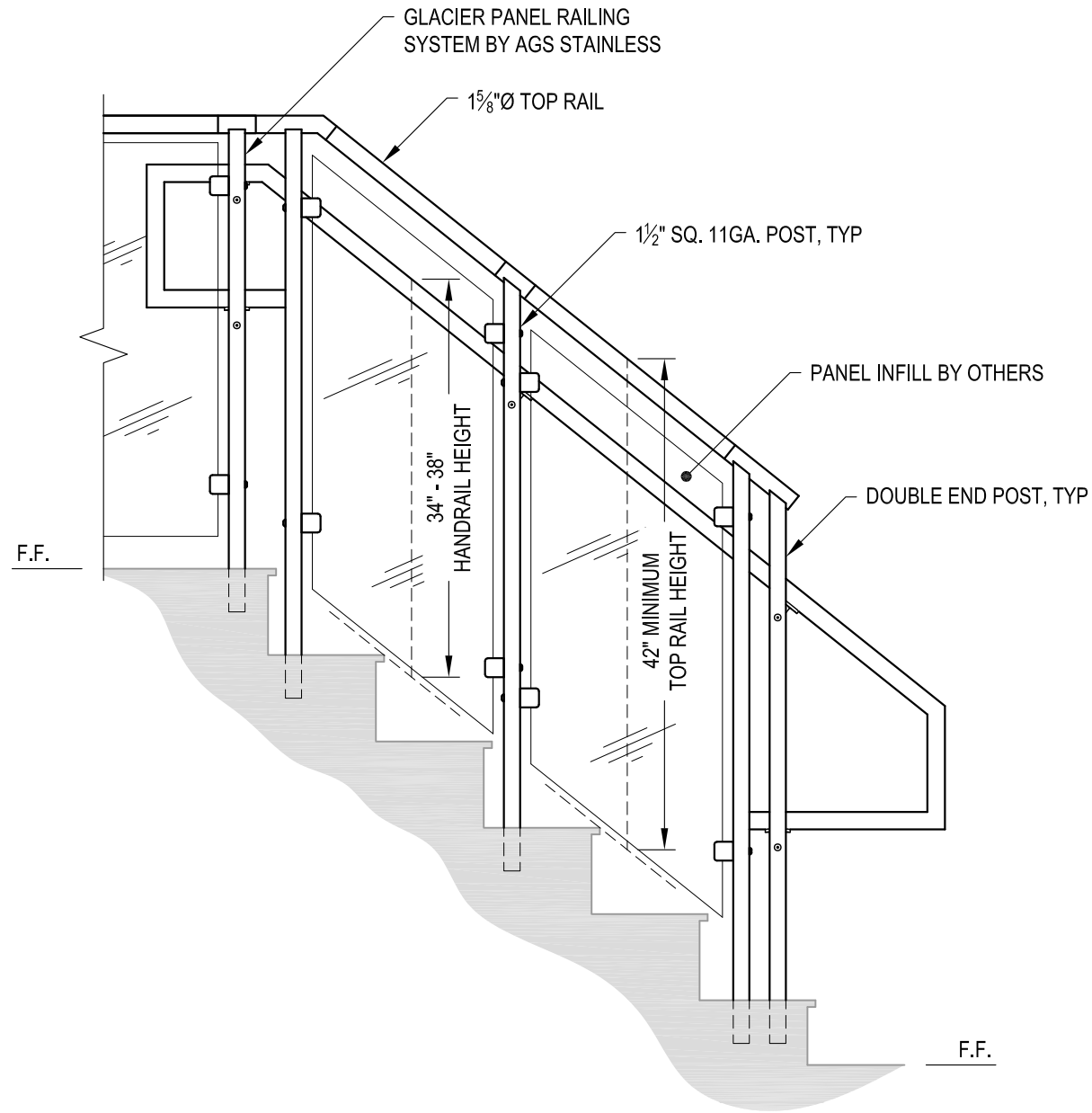

A STAIR
ELEVATION

NOTES:

1. STAIR CONSTRUCTION VARIES GREATLY. AS-BUILT CONDITIONS MAY ALTER RAILING DESIGN, INCLUDING POST LOCATION & MOUNTING, INFILL SPACING & TOP RAIL LAYOUT.

AGS Stainless Clearview® Railing Systems are designed to meet the requirements of the latest edition of the IRC/IBC.

7873 MEADY ROAD BAINBRIDGE ISLAND, WA 98110 PHONE - (888) 842-9492 FAX - (206) 842-8779 WWW.AGSSTAINLESS.COM	DWS# GLACIER CM42RC
	DATE 2024 SCALE NONE DESIGNER AGS
GLACIER SPECIFICATION DRAWING ** COMMERCIAL **	
42" CORE MOUNT - ROUND TOP	
3 OF 4	



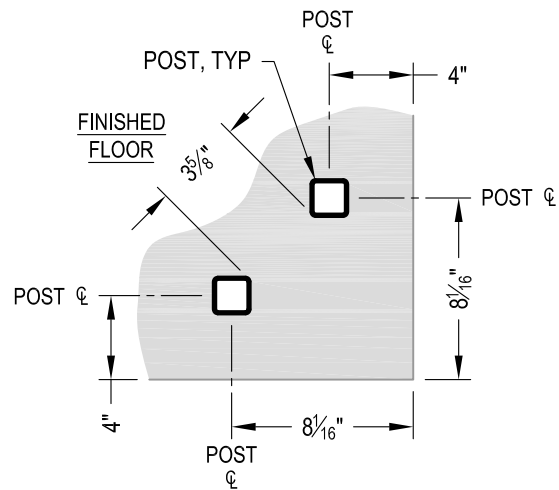

NOTE: 90° SHOWN, OTHER ANGLES SIMILAR

A TYPICAL 90° CORE MOUNT OUTSIDE CORNER DETAIL

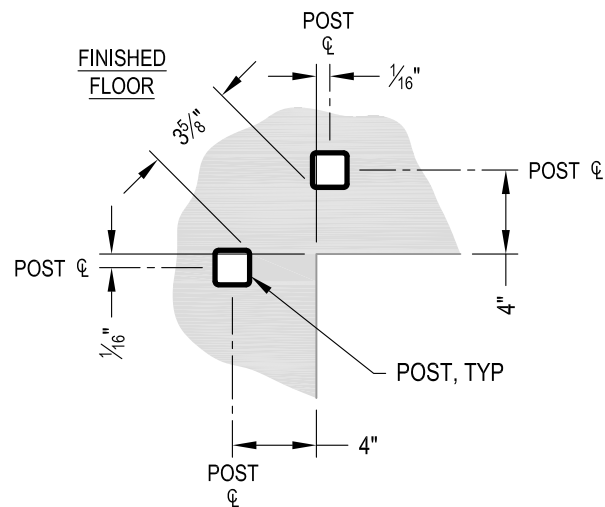

NOTE: 90° SHOWN, OTHER ANGLES SIMILAR

B TYPICAL 90° CORE MOUNT INSIDE CORNER DETAIL

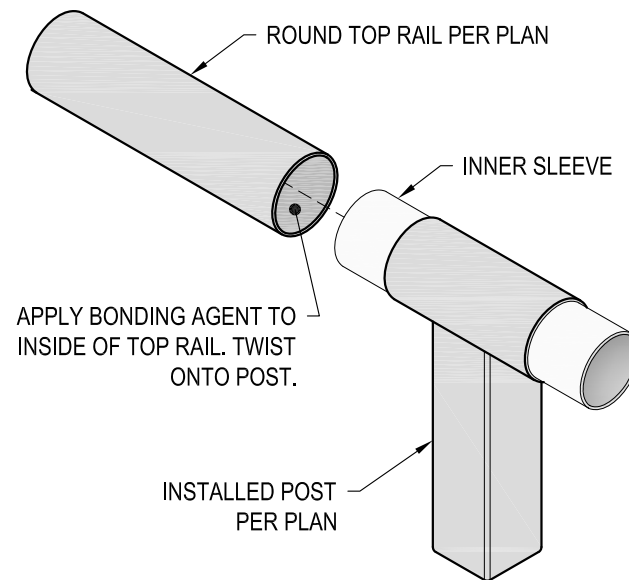

C TOP RAIL INSTALLATION - ROUND DETAIL

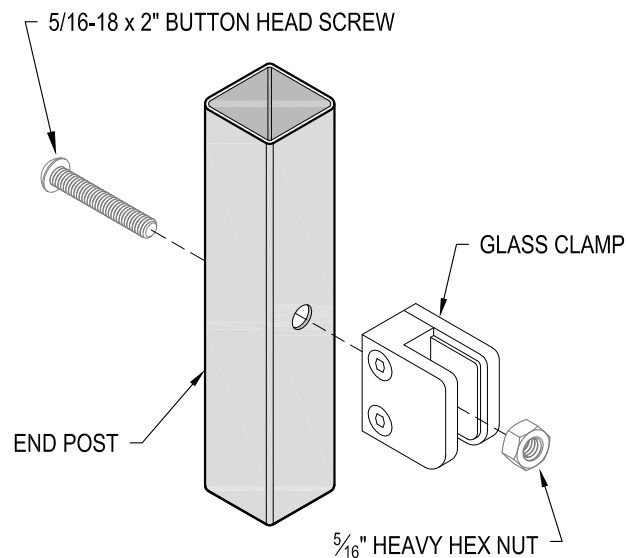

D END POST GLASS CLAMP INSTALLATION DETAIL

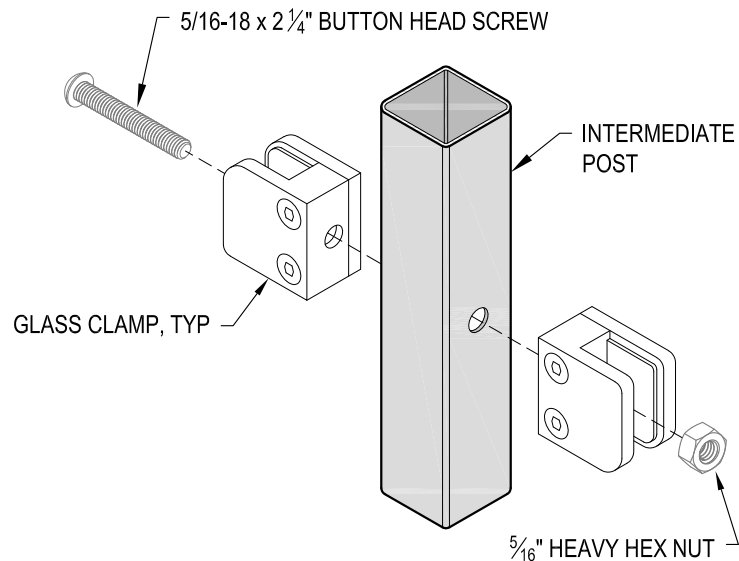

E INTERMEDIATE POST GLASS CLAMP INSTALLATION DETAIL

AGS Stainless Clearview® Railing Systems are designed to meet the requirements of the latest edition of the IRC/IBC.

DATE	GLACIER CM42RC
SCALE	NONE
DESIGNER	AGS
DATE	2024
SHEET	4 OF 4

GLACIER SPECIFICATION DRAWING
** COMMERCIAL **

42" CORE MOUNT - ROUND TOP

7873 MEADY ROAD
BAMBRIDGE ISLAND, WA 98110
PHONE - (888) 842-9492
FAX - (206) 842-8779
WWW.AGSSTAINLESS.COM

