

**1** EXAMPLE POST LAYOUT  
PLAN VIEW

**NOTES:**

1. TOP RAIL NOT SHOWN FOR CLARITY.
2. ALL PARTS AND COMPONENTS MADE WITH 316 STAINLESS STEEL UNLESS NOTED OTHERWISE.

**LEGEND**

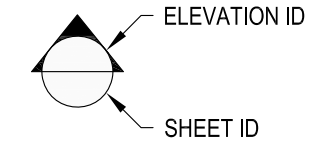
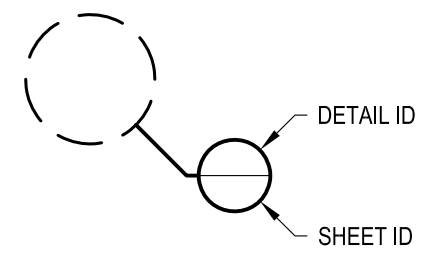

□ SIDE MOUNT POST

⊥ CENTERLINE

F.F. FINISHED FLOOR

TYP TYPICAL CONDITION APPLIES ELSEWHERE AT SIMILAR CONDITIONS

OWNER	GLACIER SM36R
SCALE	NONE
DATE	2024
DESIGNER	AGS
SHEET	1 OF 4

GLACIER SPECIFICATION DRAWING  
\*\* RESIDENTIAL \*\*  
36" SIDE MOUNT - ROUND TOP

7873 NE DAY ROAD  
BAMBRIDGE ISLAND, WA 98110  
PHONE - (888) 842-9492  
FAX - (206) 842-8779  
WWW.AGSSTAINLESS.COM



**NOTES:**

- DECK STRUCTURE CAN VARY GREATLY. IT IS THE RESPONSIBILITY OF THE CUSTOMER TO VERIFY THAT THE SUPPORTING STRUCTURE IS ADEQUATE TO MEET THE LOAD REQUIREMENTS OF THE GOVERNING BUILDING CODE(S). *AGS Stainless Inc.* RECOMMENDS CONSULTING A DESIGN OR CONSTRUCTION PROFESSIONAL TO ADDRESS THESE ISSUES.

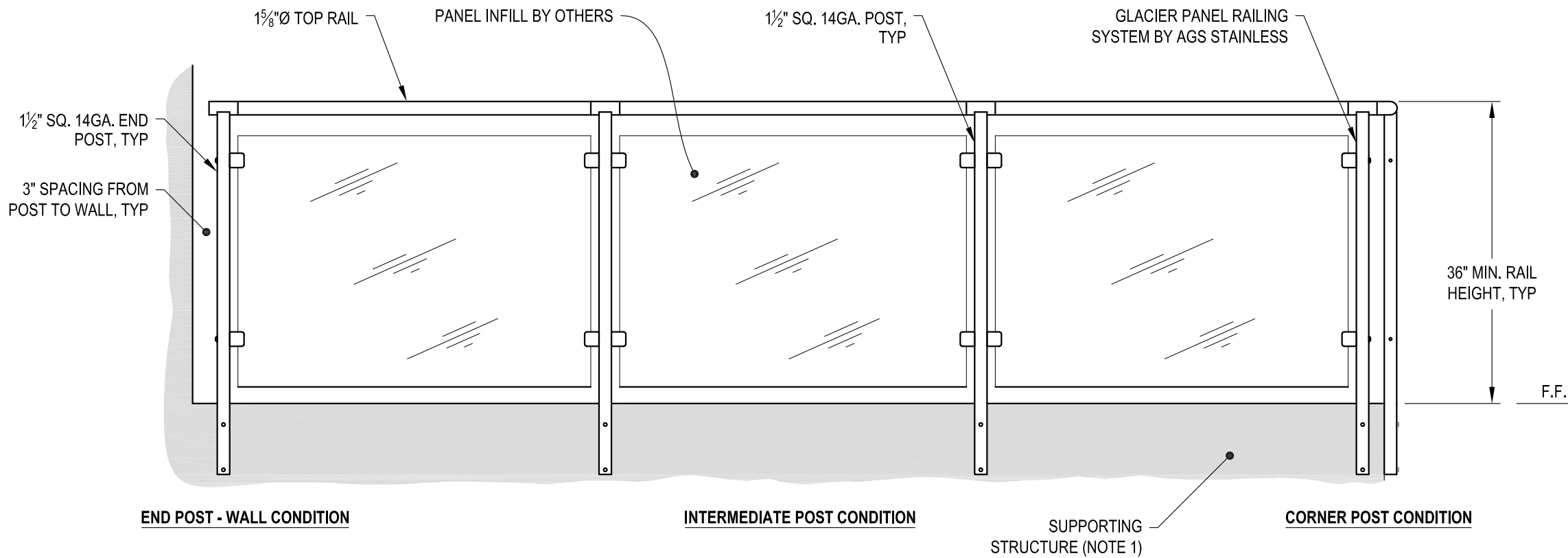

**A** TYPICAL RAILING CONDITION ELEVATION

DWS*	GLACIER SM36R	DATE	2024
	SCALE	NONE	SHEET
	DESIGNER	AGS	2 OF 4

GLACIER SPECIFICATION DRAWING  
 \*\* RESIDENTIAL \*\*  
 36" SIDE MOUNT - ROUND TOP

7873 NE DAY ROAD  
 BAINBRIDGE ISLAND, WA 98110  
 PHONE - (888) 842-9492  
 FAX - (206) 842-8779  
 WWW.AGSSTAINLESS.COM



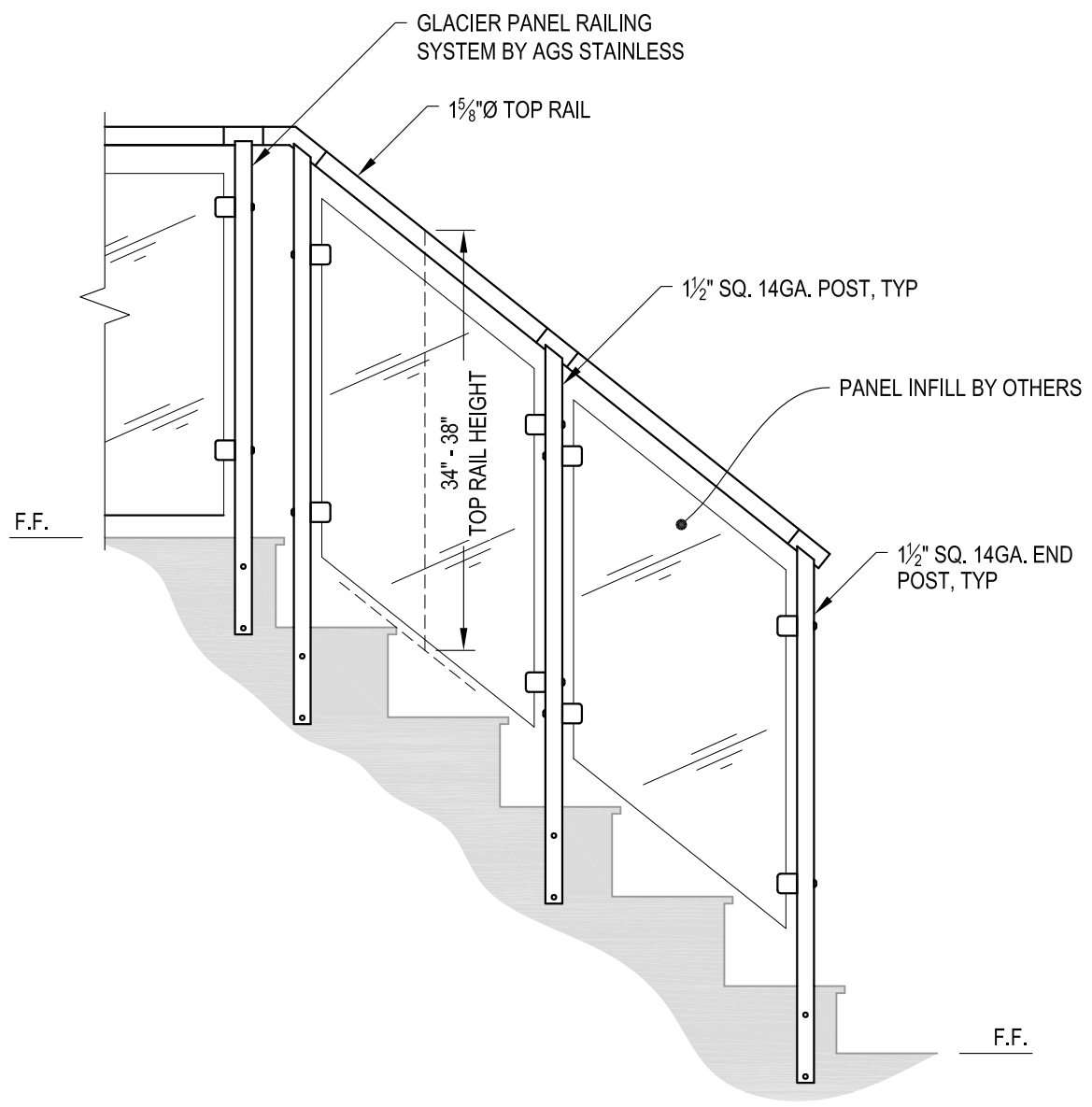

**A** STAIR  
ELEVATION

**NOTES:**

1. STAIR CONSTRUCTION VARIES GREATLY. AS-BUILT CONDITIONS MAY ALTER RAILING DESIGN, INCLUDING POST LOCATION & MOUNTING, INFILL SPACING & TOP RAIL LAYOUT.

AGS Stainless Clearview® Railing Systems are designed to meet the requirements of the latest edition of the IRC/IBC.

 <small>CLEARVIEW® Railing Systems</small>	<small>7873 MEADY ROAD BAINBRIDGE ISLAND, WA 98110 PHONE - (888) 842-9492 FAX - (206) 842-8779 WWW.AGSSTAINLESS.COM</small>	<b>GLACIER SPECIFICATION DRAWING</b> <b>** RESIDENTIAL **</b> <b>36" SIDE MOUNT - ROUND TOP</b>	<small>DATE</small> 2024 <small>DESIGNER</small> AGS
	<small>DWG#</small> GLACIER SM36R <small>SCALE</small> NONE <small>SHEET</small> 3 OF 4		

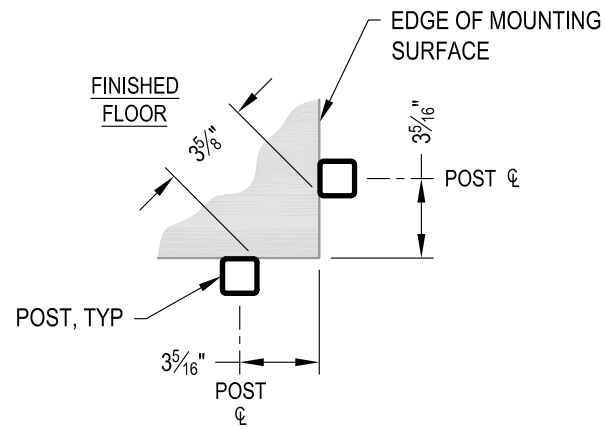

NOTE: 90° SHOWN, OTHER ANGLES SIMILAR

**A** TYPICAL SIDE MOUNT OUTSIDE CORNER  
DETAIL

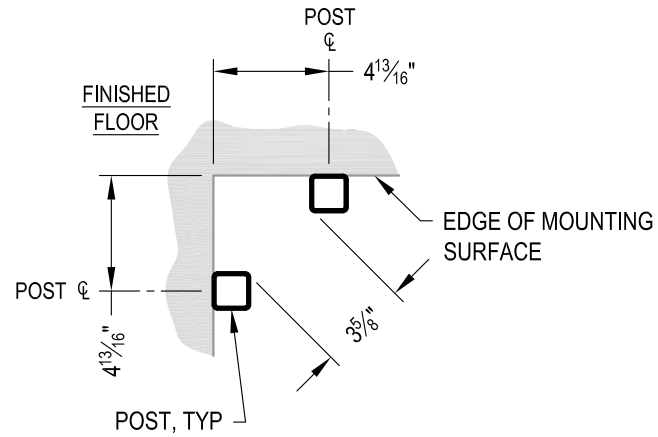

NOTE: 90° SHOWN, OTHER ANGLES SIMILAR

**B** TYPICAL SIDE MOUNT INSIDE CORNER  
DETAIL

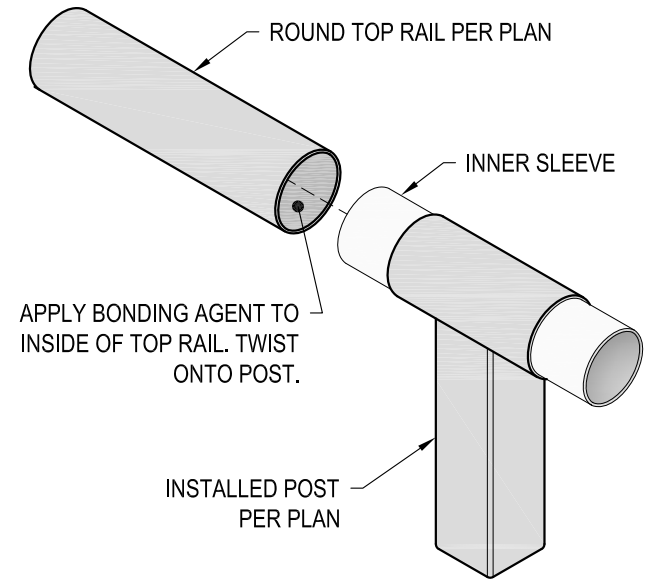

**C** TOP RAIL INSTALLATION - ROUND  
DETAIL

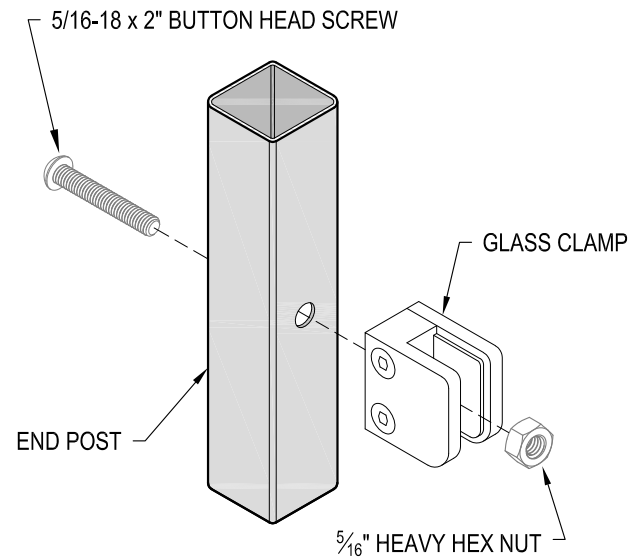

**D** END POST GLASS CLAMP INSTALLATION  
DETAIL

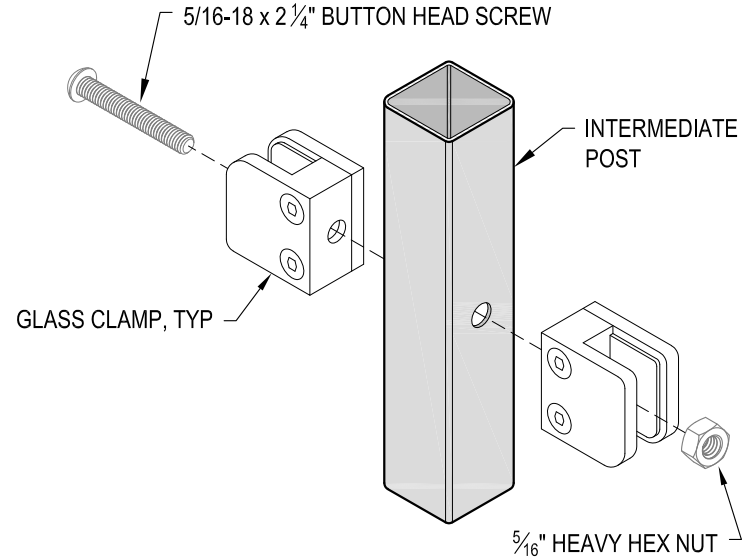

**E** INTERMEDIATE POST GLASS CLAMP INSTALLATION  
DETAIL

AGS Stainless Clearview® Railing Systems are designed to meet the requirements of the latest edition of the IRC/IBC.