

1 EXAMPLE POST LAYOUT PLAN VIEW

NOTES:

1. TOP RAIL NOT SHOWN FOR CLARITY.
2. ALL PARTS AND COMPONENTS MADE WITH 316 STAINLESS STEEL UNLESS NOTED OTHERWISE.

LEGEND

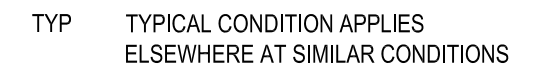
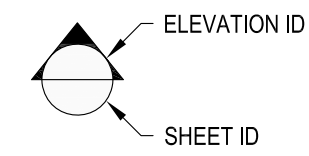
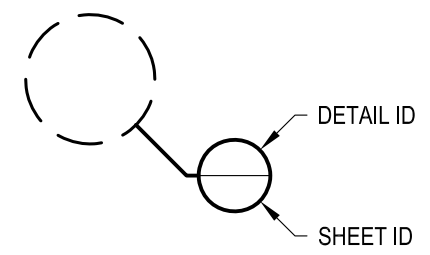

7873 NE DAY ROAD BAINBRIDGE ISLAND, WA 98110 PHONE - (888) 842-9492 FAX - (206) 842-8779 WWW.AGSSTAINLESS.COM	RAINIER TM42W	2024
	SCALE NONE DESIGNER AGS	DATE SHEET 1 OF 4
VERTICAL RAINIER SPECIFICATION DRAWING ** RESIDENTIAL **		
42" TOP MOUNT - WOOD TOP		
 CLEARVIEW® Railing Systems		

**NOTES:**

1. TOP RAIL SHOULD BE SELECTED SO THAT ALL GOVERNING CODE REQUIREMENTS ARE SATISFIED. THESE INCLUDE SHAPE, STRENGTH AND RAILING HEIGHT.
2. DECK STRUCTURE CAN VARY GREATLY. IT IS THE RESPONSIBILITY OF THE CUSTOMER TO VERIFY THAT THE SUPPORTING STRUCTURE IS ADEQUATE TO MEET THE LOAD REQUIREMENTS OF THE GOVERNING BUILDING CODE(S). AGS Stainless Inc. RECOMMENDS CONSULTING A DESIGN OR CONSTRUCTION PROFESSIONAL TO ADDRESS THESE ISSUES.

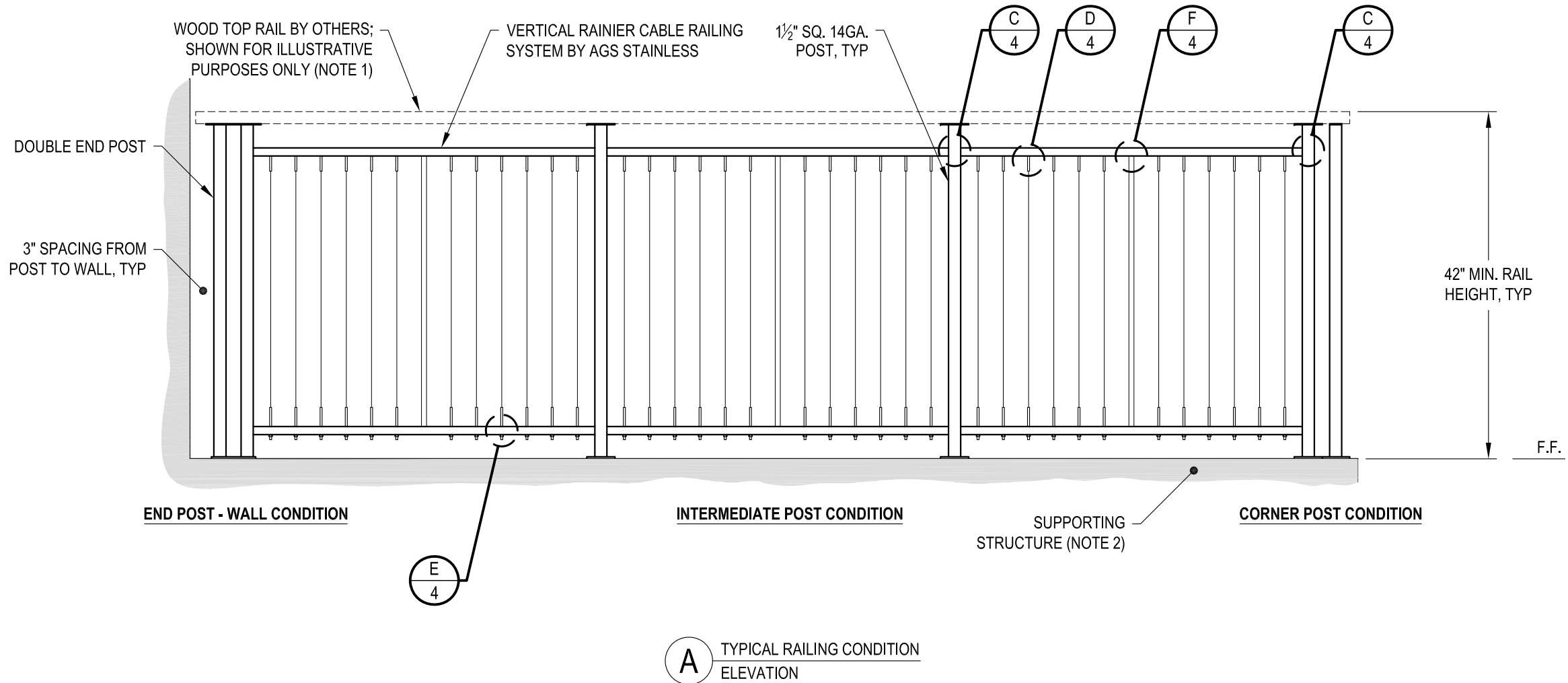

DATE	2024
SCALE	NONE
DESIGNER	AGS
SHEET	2 OF 4

VERTICAL RAINIER RAILING SPECIFICATION DRAWING  
 \*\* RESIDENTIAL \*\*

42" TOP MOUNT - WOOD TOP

7873 NE DAY ROAD  
 BAINBRIDGE ISLAND, WA 98110  
 PHONE - (888) 842-9492  
 FAX - (206) 842-8179  
 WWW.AGSTAINLESS.COM



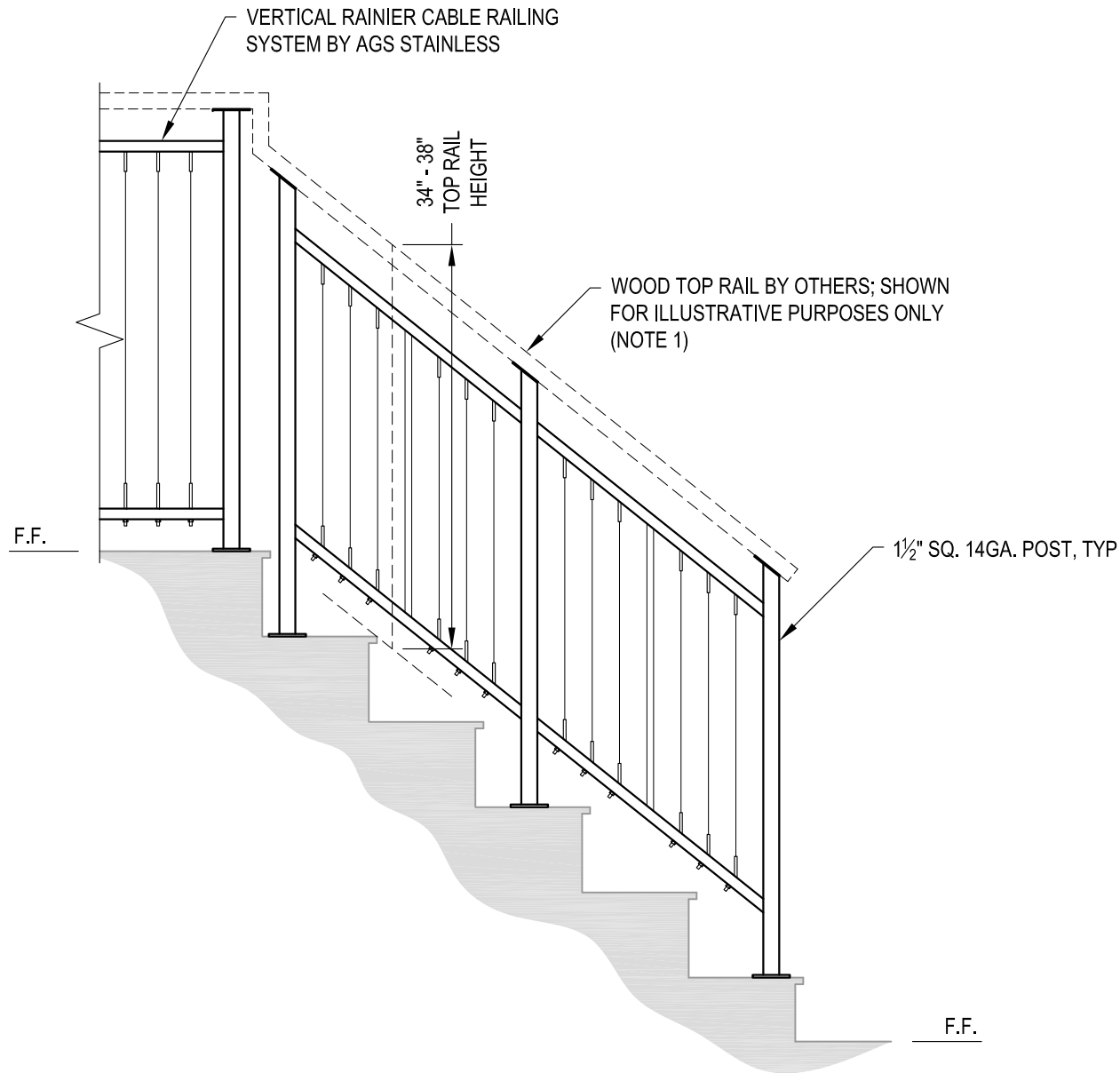

**A** STAIR  
ELEVATION

**NOTES:**

1. TOP RAIL SHOULD BE SELECTED SO THAT ALL GOVERNING CODE REQUIREMENTS ARE SATISFIED. THESE INCLUDE SHAPE, STRENGTH AND RAILING HEIGHT.
2. STAIR CONSTRUCTION VARIES GREATLY. AS-BUILT CONDITIONS MAY ALTER RAILING DESIGN, INCLUDING POST LOCATION & MOUNTING, INFILL SPACING & TOP RAIL LAYOUT.

DATE	2024
SCALE	NONE
DESIGNER	AGS
SHEET	3 OF 4

VERTICAL RAINIER SPECIFICATION DRAWING  
\*\* RESIDENTIAL \*\*

42" TOP MOUNT - WOOD TOP

7873 MEADY ROAD  
BAINBRIDGE ISLAND, WA 98110  
PHONE - (888) 842-9492  
FAX - (206) 842-8179  
WWW.AGSSTAINLESS.COM



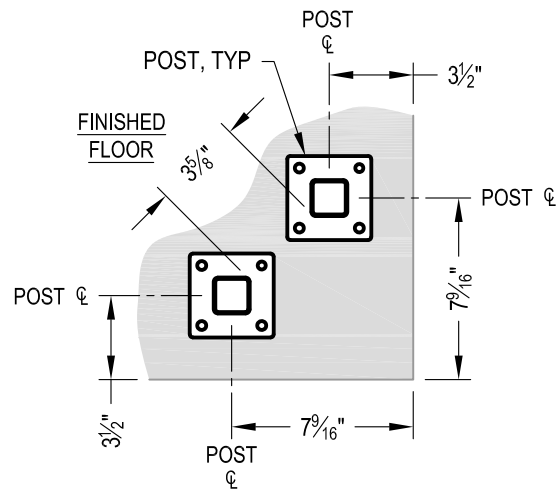

NOTE: 90° SHOWN, OTHER ANGLES SIMILAR

**A** TYPICAL 90° TOP MOUNT OUTSIDE CORNER  
DETAIL

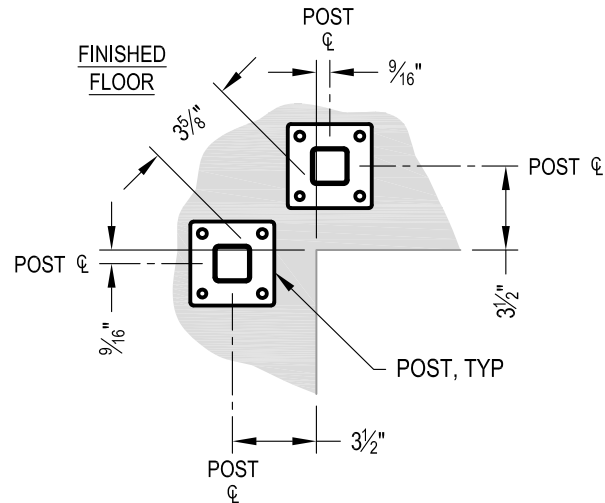

NOTE: 90° SHOWN, OTHER ANGLES SIMILAR

**B** TYPICAL 90° TOP MOUNT INSIDE CORNER  
DETAIL

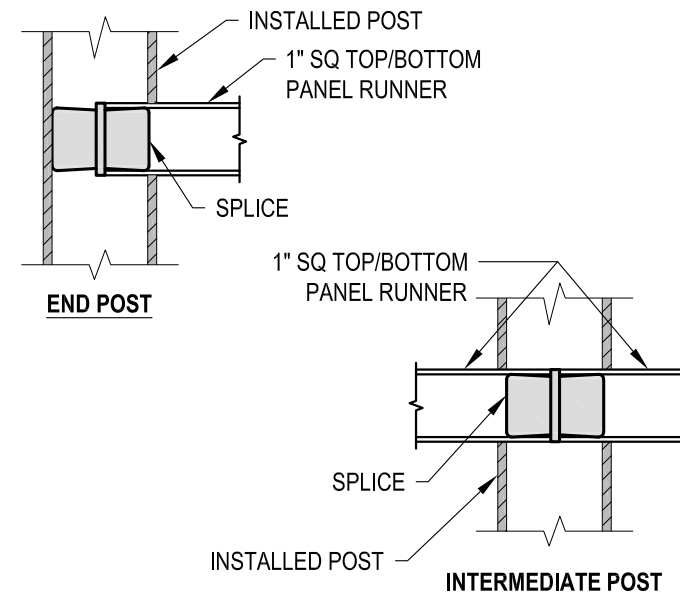

**C** FITTING INSTALLATION - VERTICAL PANEL RAIL SPLICE  
DETAIL

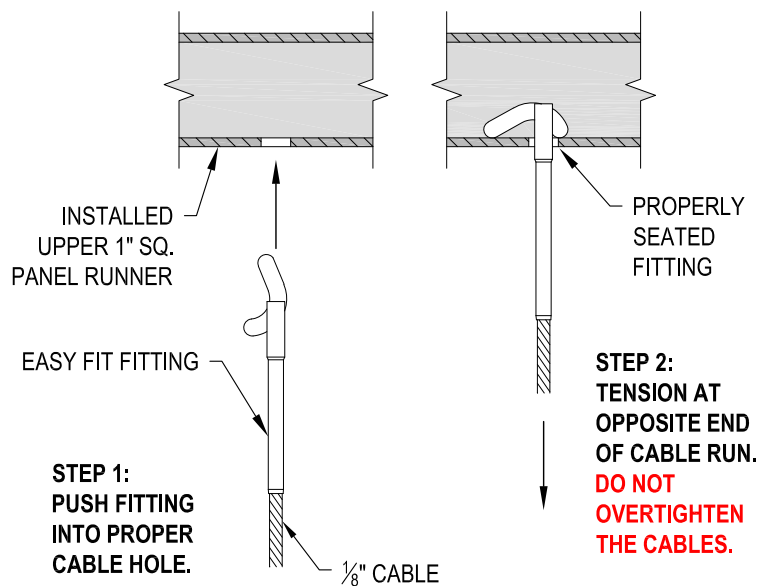

**D** FITTING INSTALLATION - EASY FIT  
DETAIL

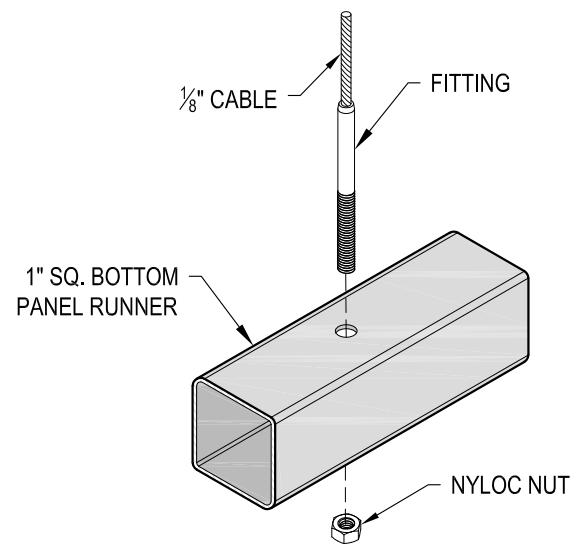

**E** FITTING INSTALLATION - STANDARD  
DETAIL

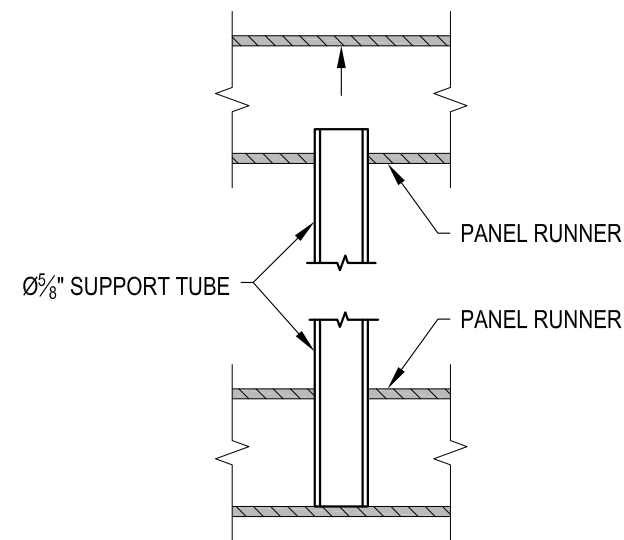

**F** PANEL SUPPORT TUBE INSTALLATION  
DETAIL

AGS Stainless Clearview® Railing Systems are designed to meet the requirements of the latest edition of the IRC/IBC.

7873 NE DAY ROAD BAINBRIDGE ISLAND, WA 98110 PHONE - (888) 842-9492 FAX - (206) 842-8179 WWW.AGSSTAINLESS.COM	RAINIER TM42W DATE 2024 SCALE NONE SHEET 4 OF 4
	AGS CLEARVIEW® Railing Systems ** RESIDENTIAL ** 42" TOP MOUNT - WOOD TOP