

1 EXAMPLE POST LAYOUT PLAN VIEW
SCALE: NONE

LEGEND

- DETAIL NUMBER
- SHEET NUMBER
- ELEVATION NUMBER
- SHEET NUMBER
- SECTION NUMBER
- SHEET NUMBER
- SIDE MOUNT POST
- CENTERLINE
- FINISHED FLOOR
- TYPICAL CONDITION; APPLIES ELSEWHERE AT SIMILAR LOCATIONS

NOTES:

1. TOP RAIL NOT SHOWN FOR CLARITY.

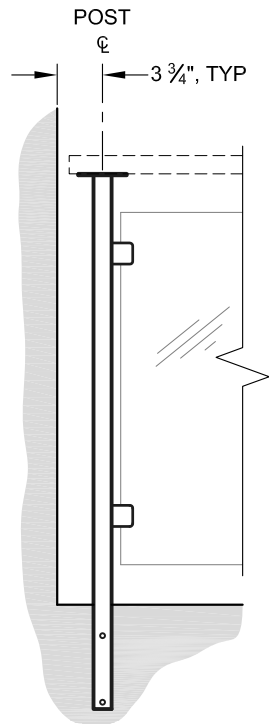

1 TYPICAL END POST ELEVATION
SCALE: NONE

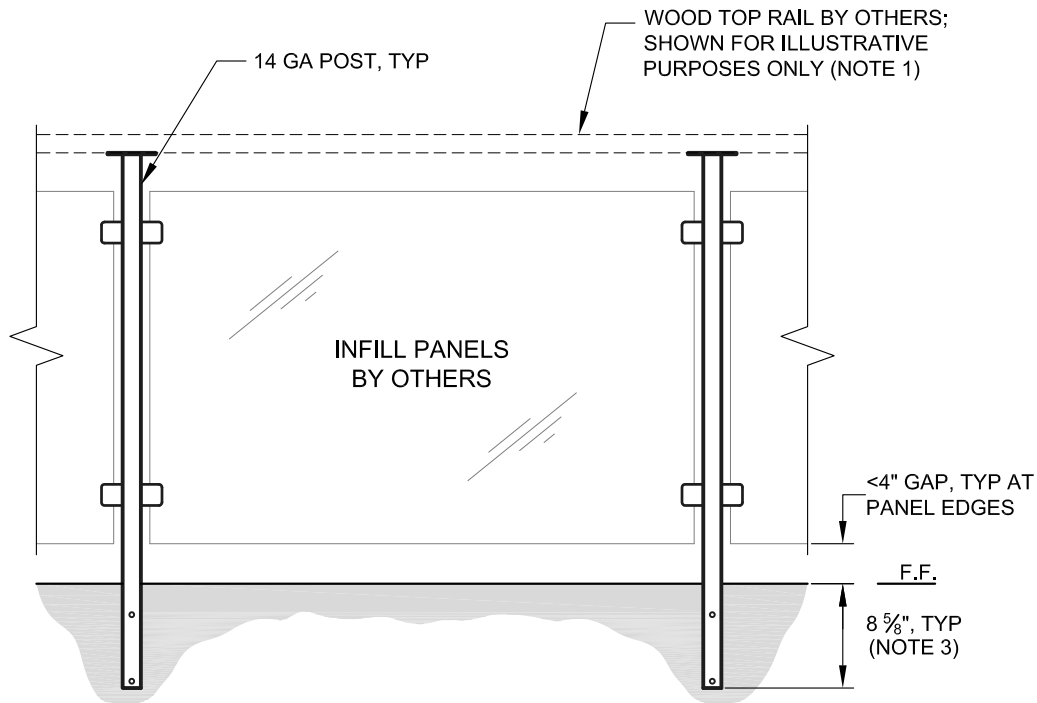

2 TYPICAL INTERMEDIATE POST ELEVATION
SCALE: NONE

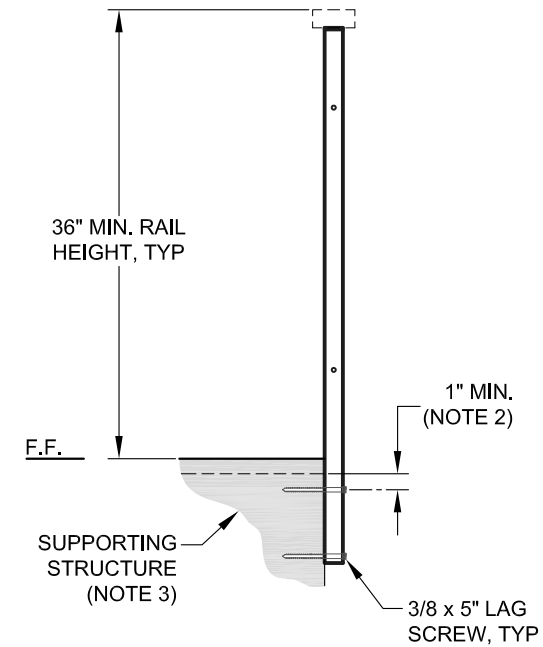

3 RAILING SECTION
SCALE: NONE

NOTES:

1. TOP RAIL SHOULD BE SELECTED SO THAT ALL GOVERNING CODE REQUIREMENTS ARE SATISFIED. THESE INCLUDE SHAPE, STRENGTH AND RAILING HEIGHT.
2. 1" MINIMUM EDGE DISTANCE MEASURED FROM THE TOP OF THE MAIN SUPPORTING MEMBER (BEAM, JOIST, FASCIA, ETC.) TO THE CENTER OF THE FASTENER.
3. DECK EDGE DETAILS CAN VARY GREATLY. IT IS THE RESPONSIBILITY OF THE CUSTOMER TO VERIFY THAT THE SUPPORTING STRUCTURE IS ADEQUATE TO MEET THE LOAD REQUIREMENTS OF THE GOVERNING BUILDING CODE(S). *AGS Stainless Inc.* RECOMMENDS CONSULTING A DESIGN OR CONSTRUCTION PROFESSIONAL TO ADDRESS THESE ISSUES.

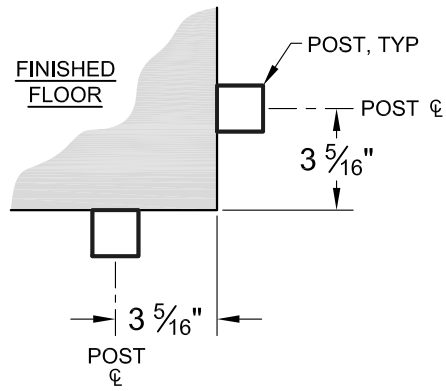

A OUTSIDE CORNER POST LAYOUT - 90°
SCALE: NONE

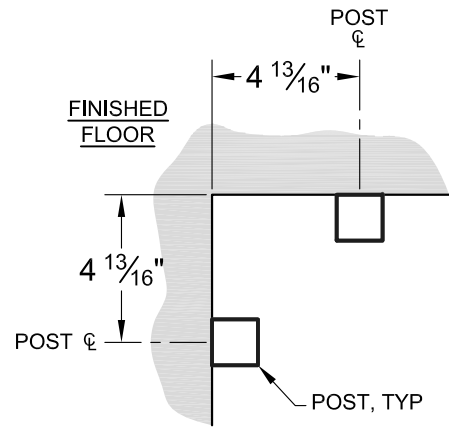

B INSIDE CORNER POST LAYOUT - 90°
SCALE: NONE

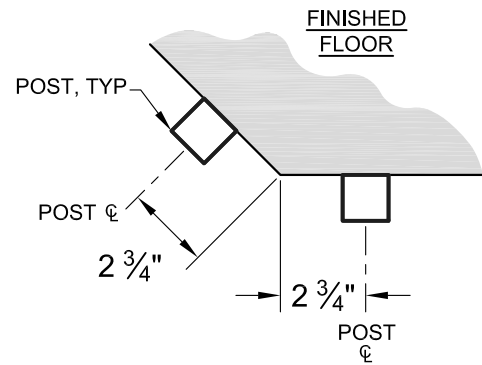

C OUTSIDE CORNER POST LAYOUT - 45°
SCALE: NONE

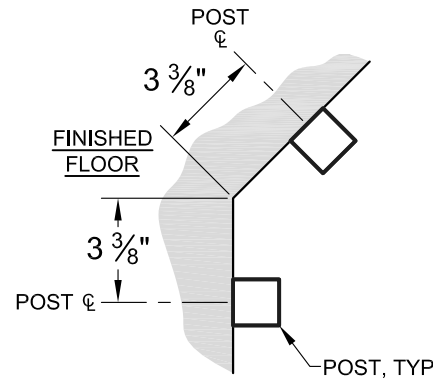

D INSIDE CORNER POST LAYOUT - 45°
SCALE: NONE

1 TYPICAL CORNER LAYOUT
SCALE: NONE

NOTE:

THE LAYOUTS SHOWN MAY VARY AS THE ANGLE CHANGES. MAKE SURE YOU CHOOSE A POST LAYOUT SO THAT TWO CLOSEST POINTS OF THE ADJACENT POSTS IS LESS THAN 4".

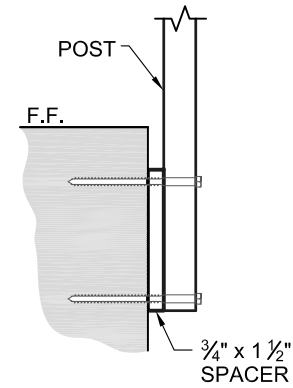

A 3/4" x 1 1/2" SPACER
SCALE: NONE

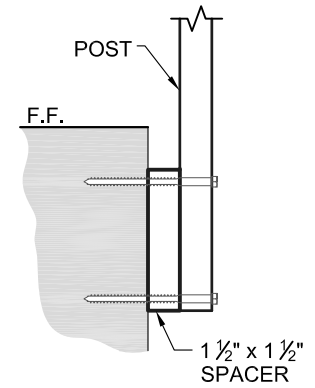

B 1 1/2" x 1 1/2" SPACER
SCALE: NONE

2 OPTIONAL SPACER DETAIL
SCALE: NONE