

Cascadia Stainless Steel Railing System (ICC-ES ESR 4148)

Installation Instructions

Before you begin:

Please read these instructions and the attached ICC-ES report, thoroughly. They address typical installations to wood supporting structure. Connections to concrete will be similar. If you have conditions not covered here, please give us a call (contact information is located at the end).

We strongly recommend watching this helpful, three-minute video: [AGSstainless.com/c-inst](https://www.agsstainless.com/c-inst).

Supporting Structure

The structure (deck, floor, stairs, etc.) to which you will be attaching your railing system needs to be capable of supporting the forces imparted on it when the railing is subjected to code-prescribed loads. *You are strongly encouraged to consult a qualified professional to make this determination and any suggestions for structural upgrades, if necessary.* Failure to do so may result in an unsafe situation that could cause serious injury or death.

Post Layout

Note: Cascadia posts are intended to mount to the finished surface. Mounting to subfloor structure may result in a non-compliant (height) system.

Locate posts so that mounting hardware adequately attaches to supporting structure (Figure 1).

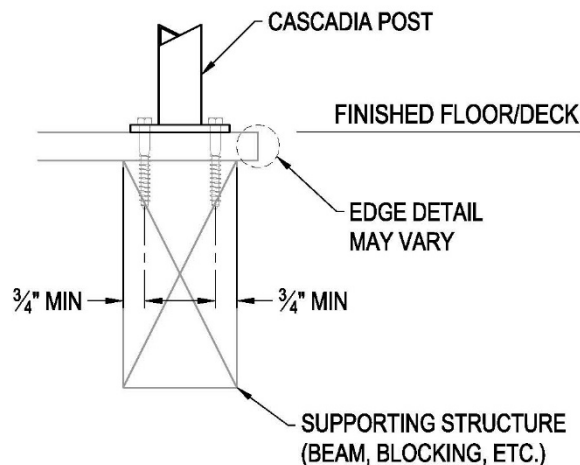

Figure 1.

End posts should be positioned so that the free end of the infill bar is not more than 9" from the center of the end post. Additionally, at a corner, the maximum gap between ends of adjacent must not exceed 1 3/4" (Figure 2).

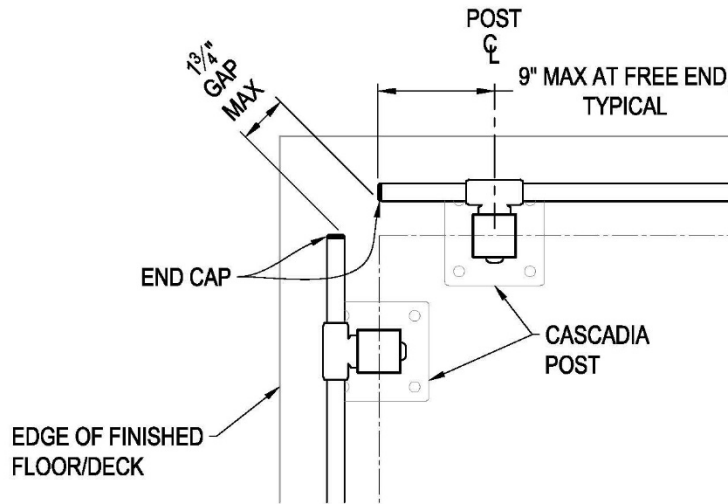

Figure 2.

For 42" systems ONLY, end-of-run conditions will require one of the following: **A.** *double* posts, **B.** continuous top rail connection, or **C.** top rail-to-wall connection (Figure 3). As with the supporting structure, it is recommended that top rail and/or wall connection details are reviewed or designed by a qualified professional. Double posts should not have more than a 3 1/2" gap.

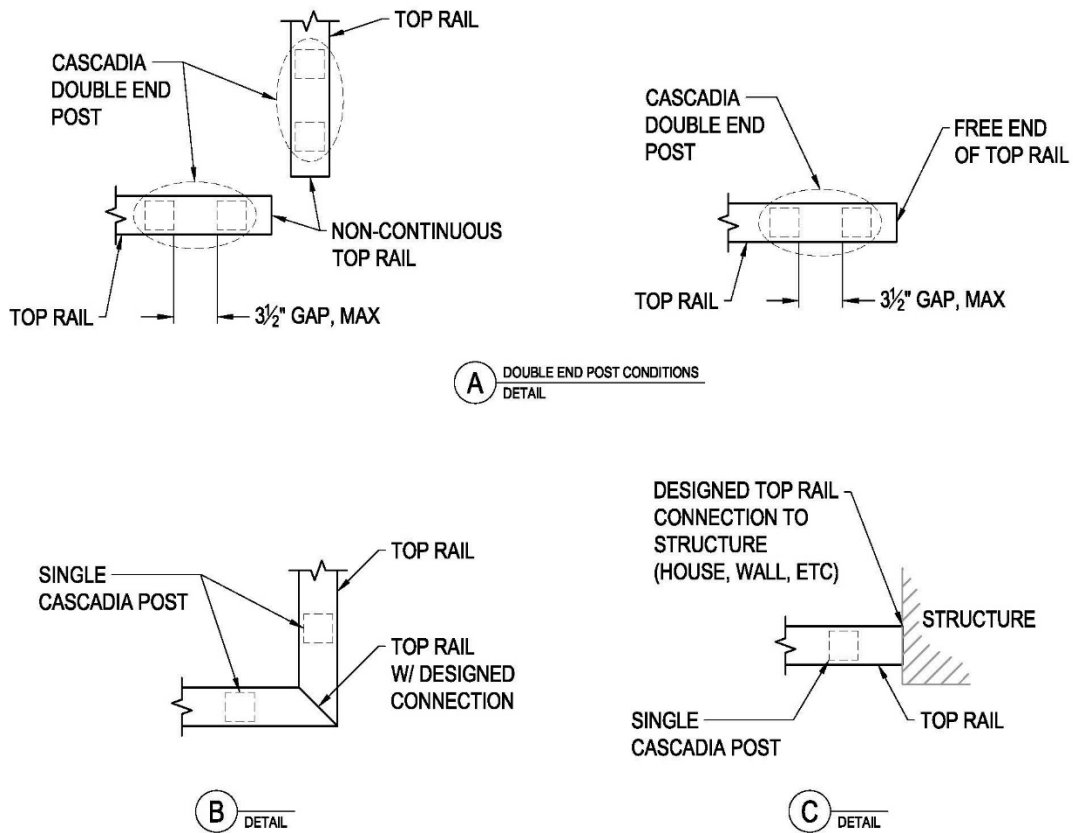

Figure 3.

Intermediate post spacing (center to center) should never exceed 3'-6". For 42" systems, spacing of posts involving a double end condition should be measured from the centerline of the inside post (Figure 4).

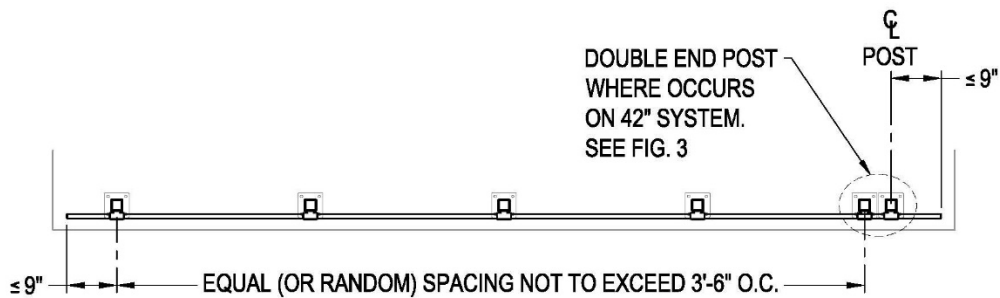

Figure 4.

Installation

PARTS LEGEND/KEY



INFILL FITTING - PART # AG3302

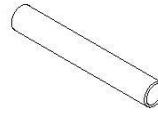

5/8" TUBE - PART # KB93

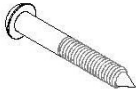

CONE TIPPED SCREW - PART # AGCT182



SS END CAP - PART # AG422



POST - PART # K36/K42

Here are the tools you will need:

- 3/16" x 12" drill bit
- Power/battery drill
- Socket wrench
- 1/2" wrench or socket
- 3/16" Allen socket
- Measuring tape
- Painter's tape
- Hack saw/Sawzall with bi-metal blade (18 or 20 teeth/inch)
- 36" straight edge
- Level
- Rubber mallet

1. Install the Posts and Base Plate Covers

Conforming to the guidelines above, place a post in position (note that the adjustable stem reducer should rotate parallel to the deck edge). Using the drill and the 12" bit, drill a hole and install one of the lag screws, *snug tight*. Rotate the post so that it is properly aligned with the edge of the deck and repeat the screw installation process for the screw located diagonally from the first screw. Then install the remaining (two) screws. With the wrench, tighten the screws, using the level to ensure the post is plumb. Take care to not mar the base plate with the wrench (if you have base plate covers, this is not as much of a concern).

Continue until all posts in a run are installed.

Posts located on stairs should follow the same guidelines as above in addition to the following (Figure 5):

- Typically, you will not want to have a post more than 3 ½" from the nosing of a stair tread.
- Stair posts, when properly located, will result in an overlap of a 6" circle and the bottom infill bar when the 6" circle touches both the riser and tread (Figure 5).
- Post spacing and free end length is measured *along the slope*.

Temporarily install the bottom infill fittings and an infill bar according to Section 3, below, but DO NOT install the screws! This is done just to check for the 6" You can use tape to hold the bar in place or have someone hold it.

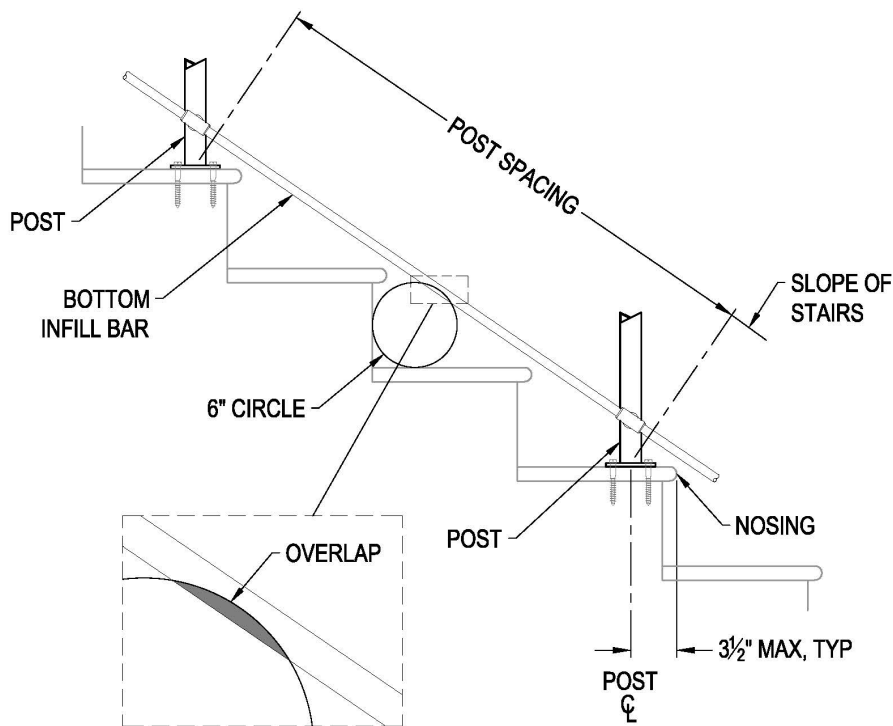

Figure 5.

If you have base plate covers, install them now. Rotate the stem reducer tops to the vertical position and slide the covers over the tops of the posts.

2. Layout and Cut the Infill Bars

Starting at an end post, place a length of bar on the finished floor/deck next to the base plates of the installed posts. Position the bar accurately (make sure you take the free end into account – see Fig. 2). At the post where the splice is to occur (splices **MUST** occur at a post), mark the bar at the center of the post (Figure 6).

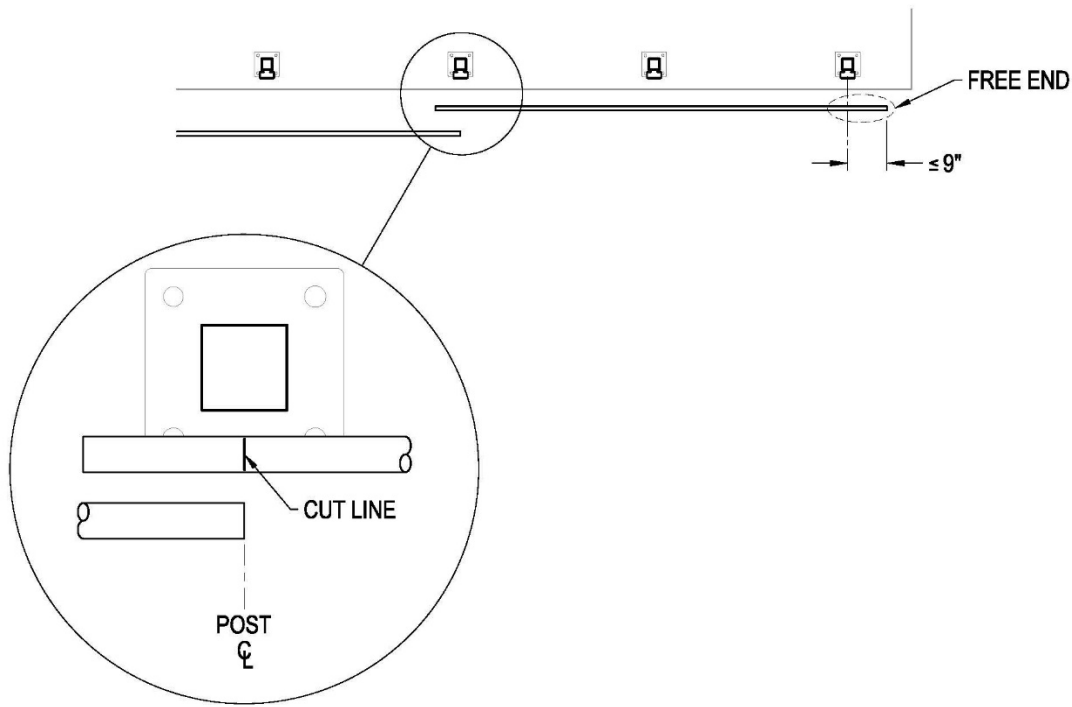

Figure 6.

Cut the bar, return it to the deck and tape it in place. Abut the next bar to the cut one and proceed to cut and tape the rest of the bars until you reach the end post, remembering to take into account the free end extension. **Make sure that each bar is supported by at least two posts.**

Review the bars on the deck. Make sure none of them have moved and that the splices are where they should be. Number each bar in sequence for reference later.

3. Install the Infill Fittings and Infill Bars

Starting with Bar #1, slide the same number of fittings onto the bar as there are posts that it engages. For example, if the bar passes by two posts, slide on two fittings. Align the fittings with the lowest holes on the posts and, with the 3/16" Allen wrench, install the cone-tipped screws from the inside face of each post. *Only engage a couple of threads*, taking care not to touch the infill bar with the tip of the screw. In the same manner, install the remaining bars in that sequence, and for each row.

At End #1, set the free end dimension for the top and bottom bars and tighten the set screw at the first post. It will be difficult to re-adjust after tightening, so make sure you are happy with the free end layout. Use the 3/16" Allen socket to seat the screw heads tight against the post. Note that you are

dimpling the infill bar so it will take some effort. Now, hold the straight edge against the top and bottom bars and slide each remaining bar up against it. Screw them in place.

Move to the opposite end of the run. Make sure that there are no gaps in the bottom and top lines of bars. Double check the free end extension and trim the splice end, if necessary. Repeat the process above and then tighten the remaining screws at the intermediate fittings.

4. Insert End Caps

With a rubber mallet, lightly tap the end caps into the ends of the infill bars. If an end cap is loose, use a flathead screwdriver to pry the tabs apart until there is a snug fit.

That's it! Repeat for remaining railing runs and install your top rail (not included) taking care to meet the requirements addressed at the beginning of this document.

For questions or comments:

206-842-9492 M-F, 8-430 PST

info@agsstainless.com



7873 Day Road W
Bainbridge Island, WA 98110